

# WE ARE MANUFACTURERS

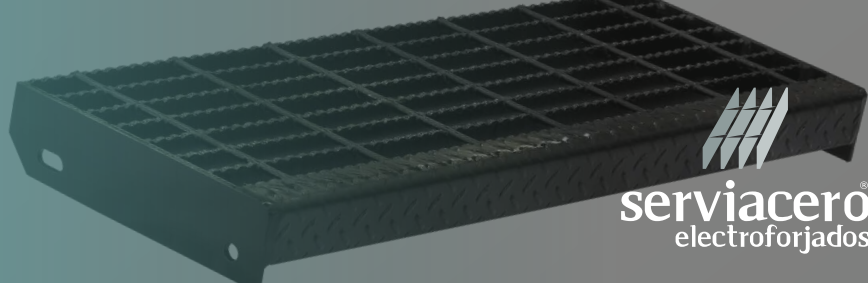

**serviacero**  
electroforjados



## ELECTROFORGED GRID STEPS

**TYPE**  
**BEARING BAR**  
**CROSS BAR**  
**SURFACE**  
**FINISHED**  
**MANUFACTURING STANDARD**  
**STEEL STANDARD**  
**GALVANIZED STANDARD**  
**NOSING THICKNESS**  
**CARRIER PLATE THICKNESS**

W19-4  
1/8" X 1 1/4"  
0.26 inch  
Flat, Serrated  
Mill, painted, galvanized  
NAAMM MBG 531 - 17  
ASTM 1011/A36  
ASTM A -123  
1/8"  
3/16"

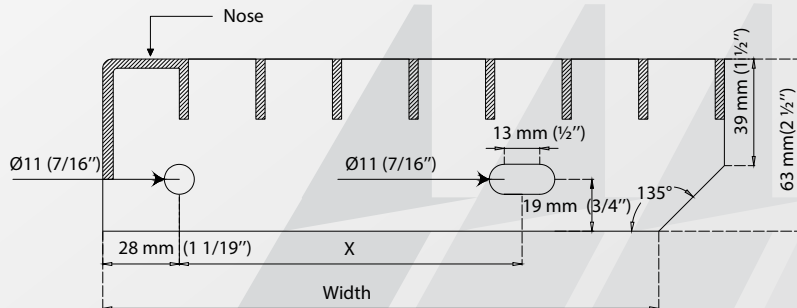
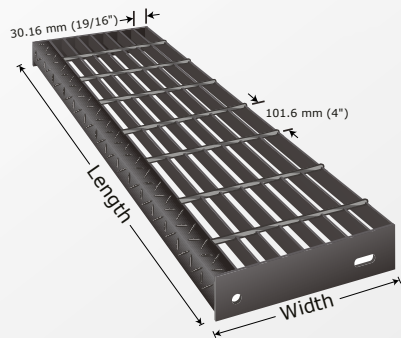

### LENGTH RECOMMENDED (MM)

#### FLAT

500 to 1040 (19 2/3 to 41)

AVAILABLE WIDTH (mm)

X DISTANCE BETWEEN HOLE CENTERS (mm)

#### SERRATED

500 to 860 (19 2/3 to 33 6/7)

220 (8 2/3") 250 (9 5/6") 280 (11") 310 (12 1/5")

114 (4 1/2") 178 (7") 178 (7") 178 (7")

Planta León, Tel. (477) 478 29 00  
electroforjados@serviacero.com  
www.serviacero.com/electroforjados



# WE ARE MANUFACTURERS

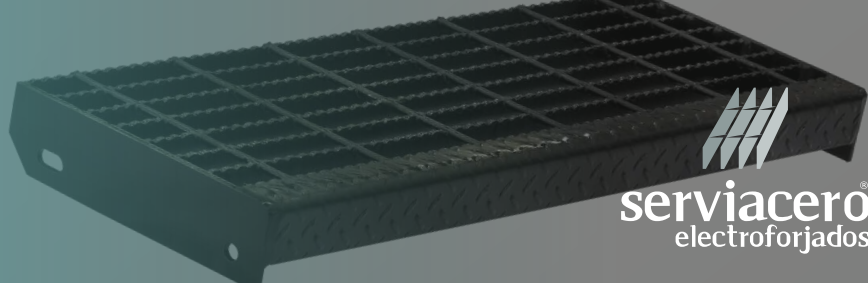

**serviacero**  
electroforjados



## ELECTROFORGED GRID STEPS

**TYPE**  
BEARING BAR  
**CROSS BAR**  
SURFACE  
FINISHED  
MANUFACTURING STANDARD  
STEEL STANDARD  
GALVANIZED STANDARD  
NOSING THICKNESS  
CARRIER PLATE THICKNESS

W19 - 4  
1/8" X 1"  
0.26 inch  
Flat, Serrated  
Mill, painted, galvanized  
NAAMM MBG 531 - 17  
ASTM 1011/A36  
ASTM A -123  
1/8"  
3/16"

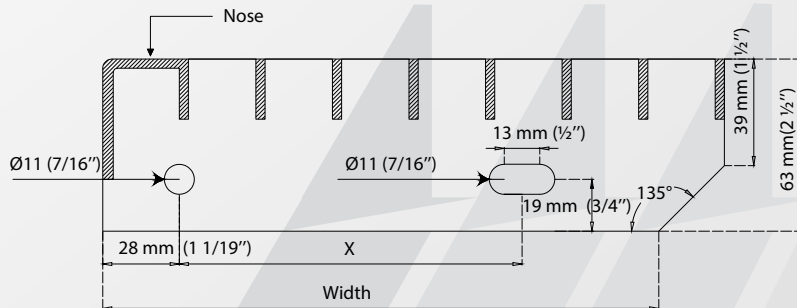
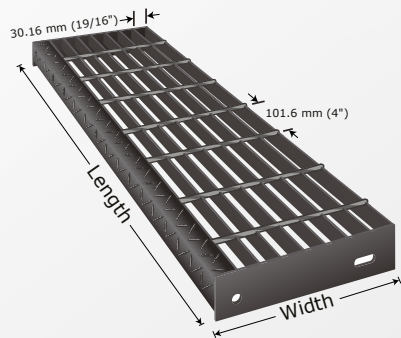

### LENGTH RECOMMENDED (MM)

**FLAT**

**SERRATED**

500 to 800 (19 2/3 to 31 1/2)

500 to 710 (19 2/3 to 28)

**AVAILABLE WIDTH (mm)**

220 (8 2/3") 250 (9 5/6") 280 (11") 310 (12 1/5")

**X DISTANCE BETWEEN HOLE CENTERS (mm)**

114 (4 1/2") 178 (7") 178 (7") 178 (7")

Planta León, Tel. (477) 478 29 00  
electroforjados@serviacero.com  
www.serviacero.com/electroforjados



# WE ARE MANUFACTURERS

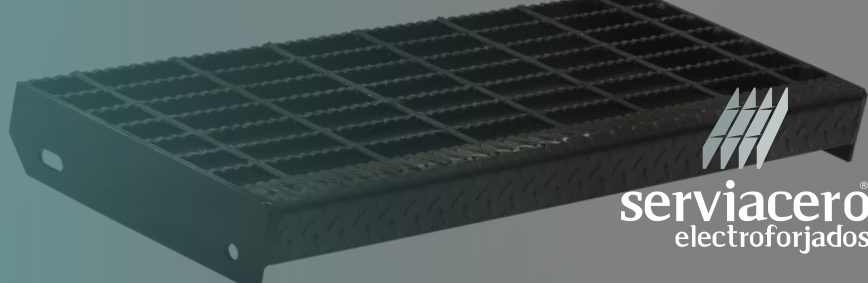

**serviacero**  
electroforjados



## ELECTROFORGED GRID STEPS

**TYPE**  
**BEARING BAR**  
**CROSS BAR**  
**SURFACE**  
**FINISHED**  
**MANUFACTURING STANDARD**  
**STEEL STANDARD**  
**GALVANIZED STANDARD**  
**NOSING THICKNESS**  
**CARRIER PLATE THICKNESS**

W19 - 4  
3/16" X 1 1/2"  
0.26 inch  
Flat, Serrated  
Mill, painted, galvanized  
NAAMM MBG 531 - 17  
ASTM 1011/A36  
ASTM A -123  
1/8"  
3/16"

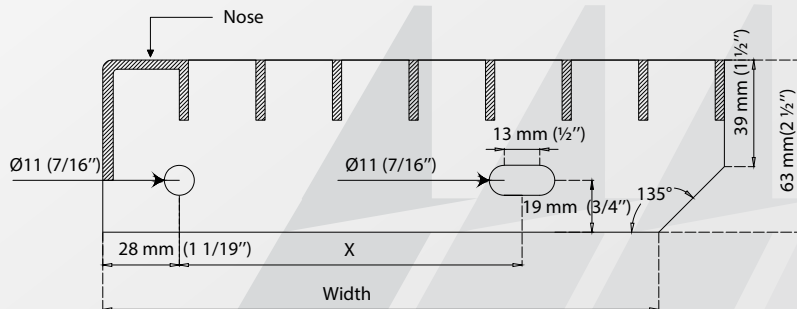
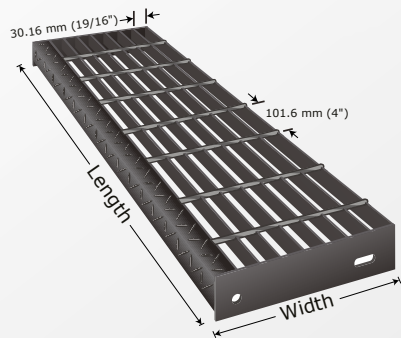

### LENGTH RECOMMENDED (MM)

#### FLAT

500 to 1670 (19 2/3 to 63)

#### AVAILABLE WIDTH (mm)

X DISTANCE BETWEEN HOLE CENTERS (mm)

#### SERRATED

500 to 1600 (19 2/3 to 65 3/4)

220 (8 2/3") 250 (9 5/6") 280 (11") 310 (12 1/5")

114 (4 1/2") 178 (7") 178 (7") 178 (7")

Planta León, Tel. (477) 478 29 00  
electroforjados@serviacero.com  
www.serviacero.com/electroforjados



# WE ARE MANUFACTURERS

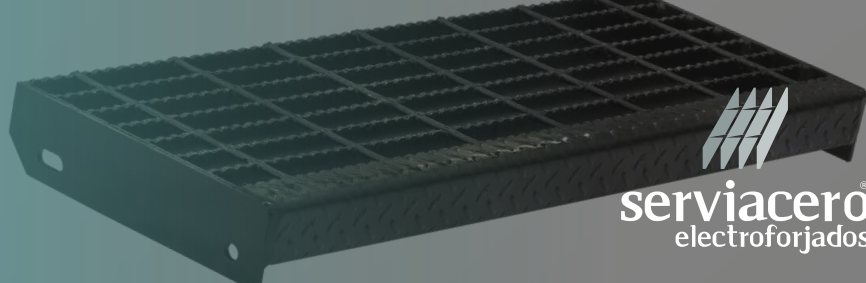

**serviacero**  
electroforjados



## ELECTROFORGED GRID STEPS

**TYPE**  
**BEARING BAR**  
**CROSS BAR**  
**SURFACE**  
**FINISHED**  
**MANUFACTURING STANDARD**  
**STEEL STANDARD**  
**GALVANIZED STANDARD**  
**NOSING THICKNESS**  
**CARRIER PLATE THICKNESS**

W19 - 4  
3/16" X 1 1/4"  
0.26 inch  
Flat, Serrated  
Mill, painted, galvanized  
NAAMM MBG 531 - 17  
ASTM 1011/A36  
ASTM A -123  
1/8"  
3/16"

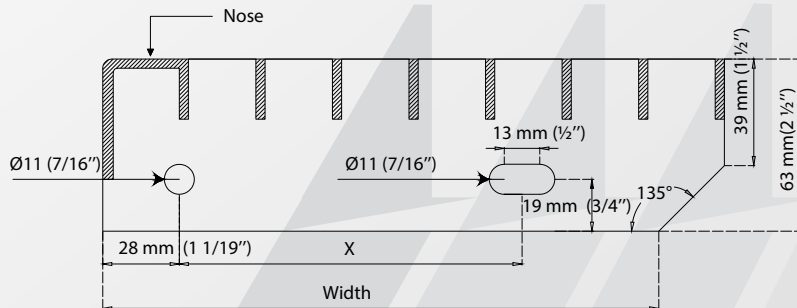
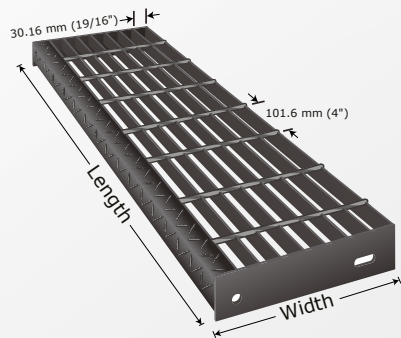

### LENGTH RECOMMENDED (MM)

#### FLAT

500 to 1420 (19 2/3 to 56)

AVAILABLE WIDTH (mm)

X DISTANCE BETWEEN HOLE CENTERS (mm)

#### SERRATED

500 to 1270 (19 2/3 to 50)

220 (8 2/3") 250 (9 5/6") 280 (11") 310 (12 1/5")

114 (4 1/2") 178 (7") 178 (7") 178 (7")

Planta León, Tel. (477) 478 29 00  
electroforjados@serviacero.com  
www.serviacero.com/electroforjados



# WE ARE MANUFACTURERS

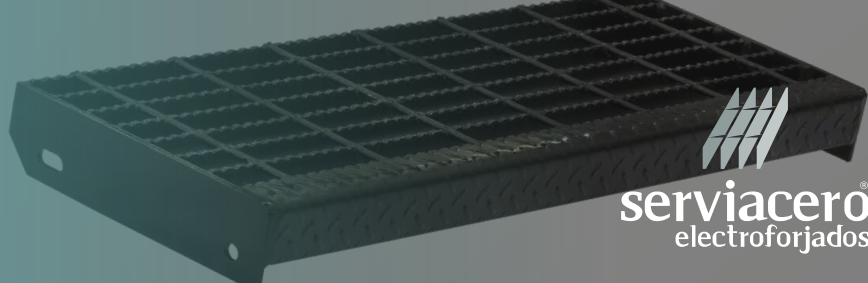

**serviacero**  
electroforjados

## ELECTROFORGED GRID STEPS

**TYPE**  
**BEARING BAR**  
**CROSS BAR**  
**SURFACE**  
**FINISHED**  
**MANUFACTURING STANDARD**  
**STEEL STANDARD**  
**GALVANIZED STANDARD**  
**NOSING THICKNESS**  
**CARRIER PLATE THICKNESS**

W19 - 4  
3/16" X 1"  
0.26 inch  
Flat, Serrated  
Mill, painted, galvanized  
NAAMM MBG 531 - 17  
ASTM 1011/A36  
ASTM A -123  
1/8"  
3/16"

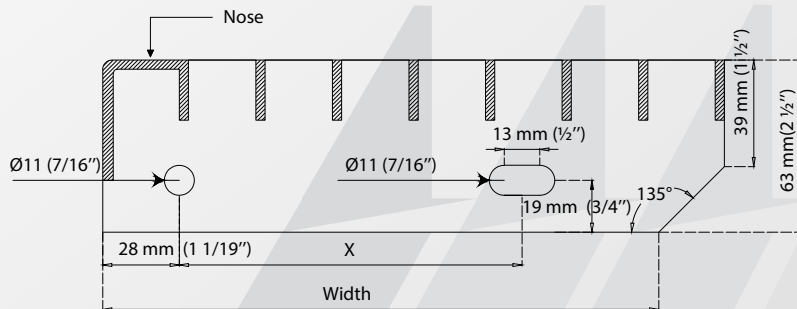
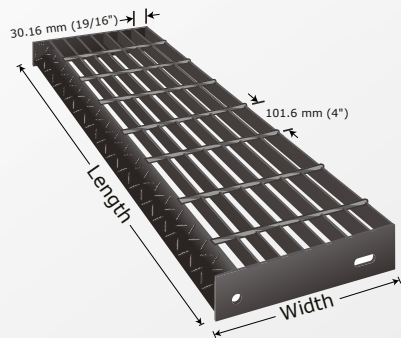

### LENGTH RECOMMENDED (MM)

#### FLAT

500 to 1040 (19 2/3 to 41)

AVAILABLE WIDTH (mm)

X DISTANCE BETWEEN HOLE CENTERS (mm)

#### SERRATED

500 to 860 (19 2/3 to 33 6/7)

220 (8 2/3") 250 (9 5/6") 280 (11") 310 (12 1/5")

114 (4 1/2") 178 (7") 178 (7") 178 (7")

Planta León, Tel. (477) 478 29 00  
electroforjados@serviacero.com  
www.serviacero.com/electroforjados



# WE ARE MANUFACTURERS

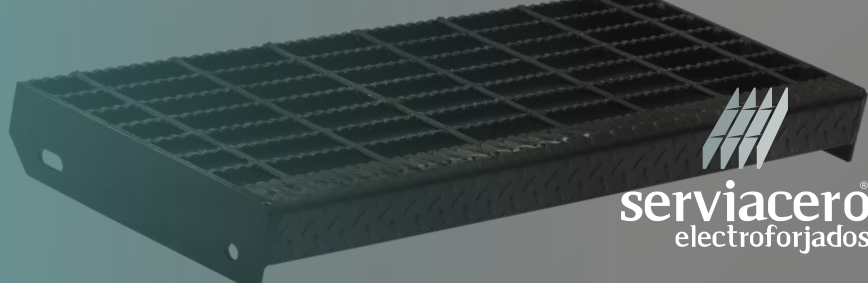

**serviacero**  
electroforjados

## ELECTROFORGED GRID STEPS

**TYPE**  
**BEARING BAR**  
**CROSS BAR**  
**SURFACE**  
**FINISHED**  
**MANUFACTURING STANDARD**  
**STEEL STANDARD**  
**GALVANIZED STANDARD**  
**NOSING THICKNESS**  
**CARRIER PLATE THICKNESS**

W19 - 4  
3/16" X 3/4"  
0.26 inch  
Flat, Serrated  
Mill, painted, galvanized  
NAAMM MBG 531 - 17  
ASTM 1011/A36  
ASTM A -123  
1/8"  
3/16"

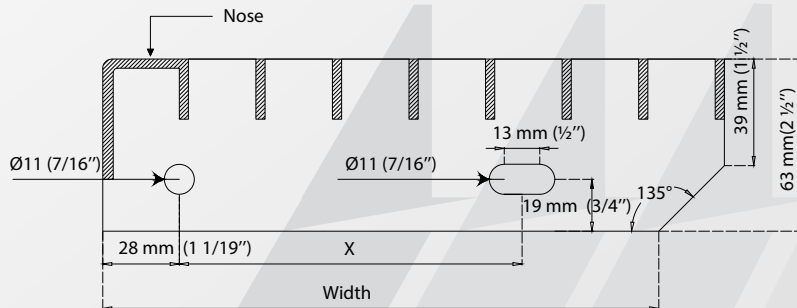
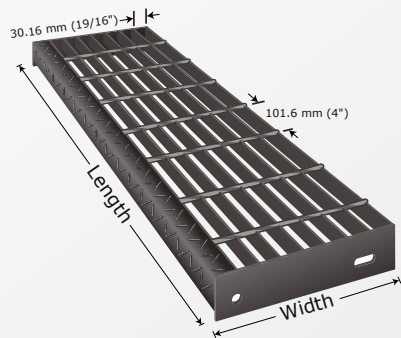

### LENGTH RECOMMENDED (MM)

500 to 710 (19 2/3 to 28)

AVAILABLE WIDTH (mm)

220 (8 2/3") 250 (9 5/6") 280 (11") 310 (12 1/5")

X DISTANCE BETWEEN HOLE CENTERS (mm)

114 (4 1/2") 178 (7") 178 (7") 178 (7")

Planta León, Tel. (477) 478 29 00  
electroforjados@serviacero.com  
www.serviacero.com/electroforjados

